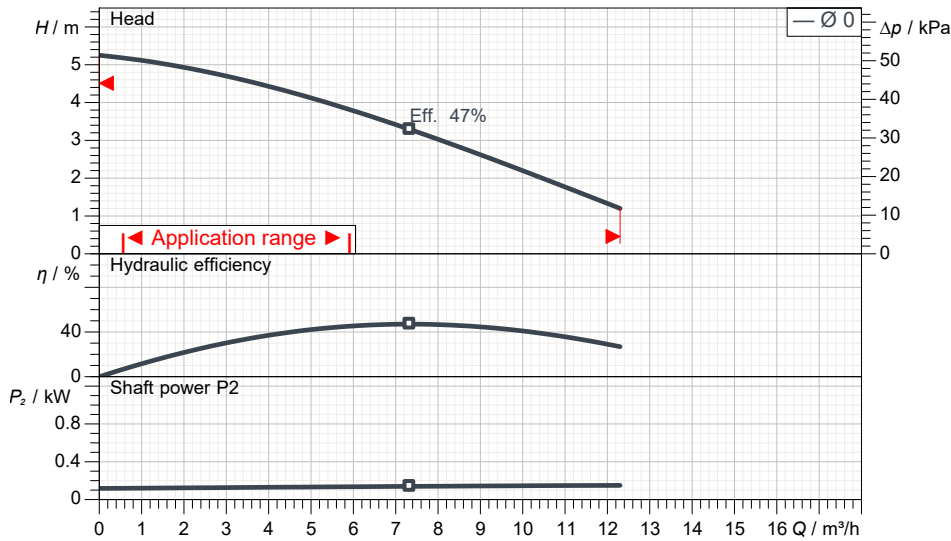

40PU2.15S-55 220-240V
Technical specification
1~ 50 Hz

Pump

Series	PU
Pump name	40PU2.15S-55 220-240V
Standard	N/A

Motor data

Motor	TT1-2-0.15S-PU <D>
Rated voltage	220 V
Frequency	50 Hz
Motor phases	1~
Number of poles	2
Rated power P_2	0.15 kW
Rated current	1.7 A
rpm	2852 1/min
Rated torque	0.5 Nm
Start*	

Degree of protection	IP 68
Insulation class	E
Protection device	Miniature protector
Type of oil	Liquid Paraffin(ISO VG32)
Oil amount	0.135 l

Hydraulic

Free passage	35 mm
Impeller type	Vortex impeller
Max. hydraulic efficiency	47.0 %
Discharge	40 mm
Curve tolerance	UNI EN ISO 9906:2012

Operating limits (standard pumps)

Max. ambient temperature	
Max. density treated liquid	1030 kg/m ³
pH treated liquid	5-9
Max. start per hour (equally distributed)	10
Wet/dry use	WET
Operating mode	S1

Construction materials

Motor enclosure	304 Stainless Steel
Shaft	316 Stainless Steel
Pump Casing	
Impeller	PPO resin with glass fiber
Suction Cover	
Painting	
Screws	304 Stainless Steel
Gaskets	NBR

Construction features

Power cable1	3C*0.75mm ²
Power cable2	N/A
Sheath	H05VV-F
Control cable	N/A
Sheath	N/A
Cable length	5 m
Mechanical seals	D-12RC
Weight*	5.3 kg

* cable and fixing system excluded

Monitoring features

Monitoring option	
leaking sensor -	
monitoring equipment -	

40PU2.15S-55 220-240V
Pump performance curves
3 ~ 50 Hz

Discharge	Head	Capacity	Rated power	Voltage	Current	rpm
40 mm			0.2 kW	220 V	1.7 A	2852 1/min

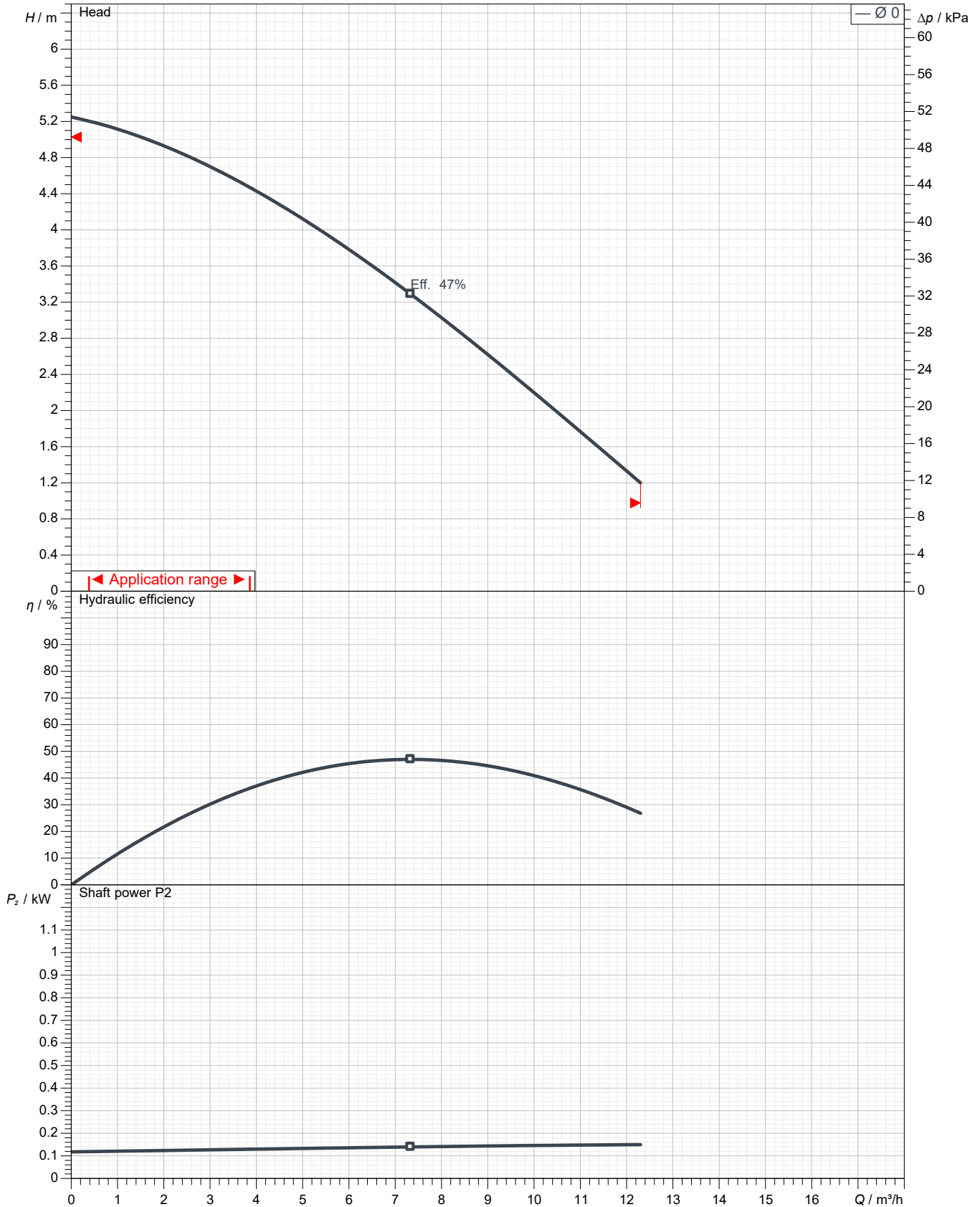
 Characteristic curves according to UNI EN ISO 9906:2012 for pumps with standard material combination
 P₂<10kW: paragraph 4.4.2
 10kW<P₂<100kW: Grade 3B
 P₂>100kW: Grade 2B

DIMENSION DRAWING		No.	No.	A-27590-25S
TYPE	Submersible Resin-made Sewage & Wastewater Pump	MODEL	40PU2.15S -55	

Approximate Weight(※)
5.3kg

※excluding cable

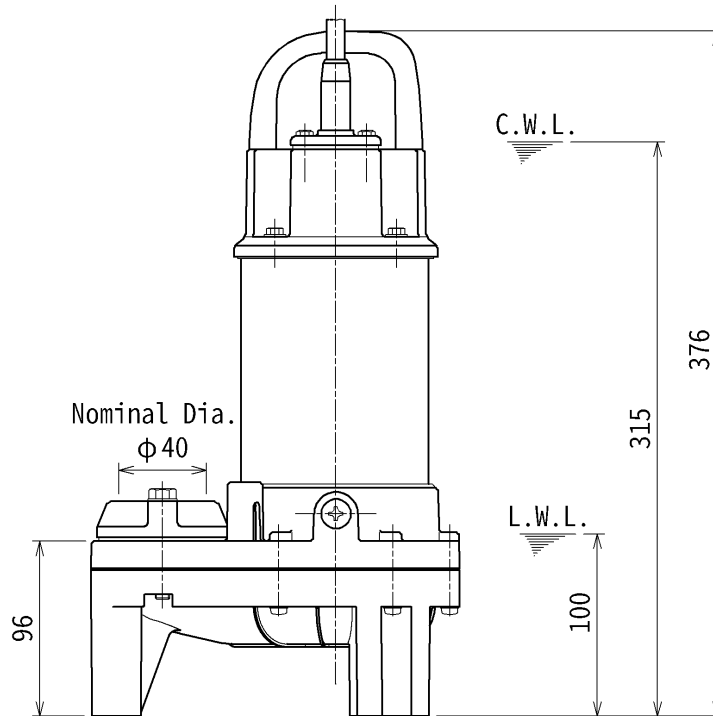
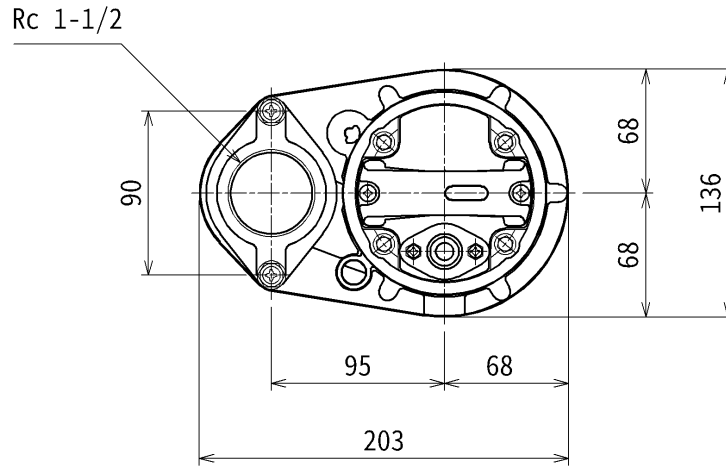

C.W.L.:Continuous running Water Level
L.W.L.:Lowest running Water Level

TSURUMI MFG. CO., LTD.

unit:mm

Created on: 2025-03-11

SECTIONAL DRAWING		No.	No.	A-27592-35
TYPE	Submersible Resin-made Sewage & Wastewater Pump	MODEL	40PU2.15S -55	

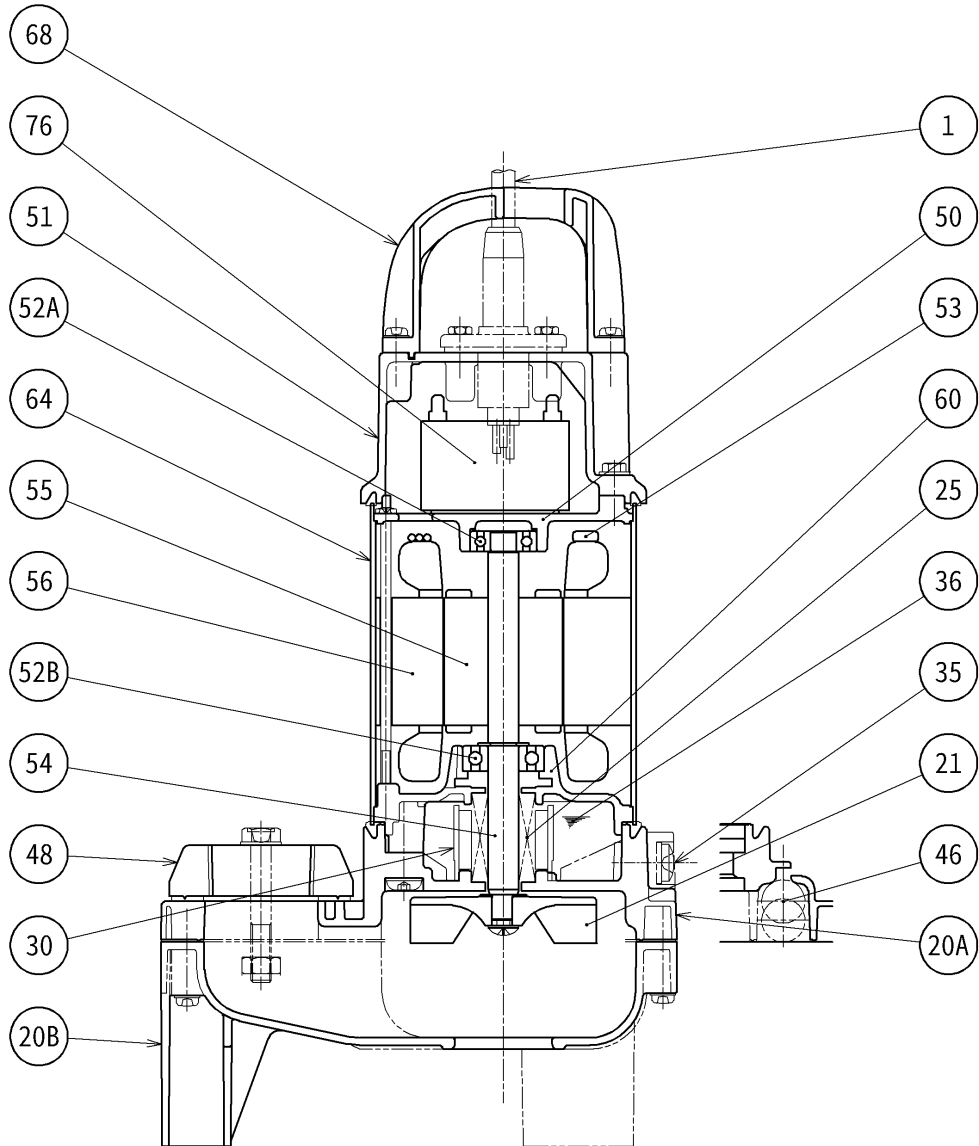

REQ. SPECIFICATION	

No.	DESCRIPTION	Q'TY	MATERIAL / NOTE	No.	DESCRIPTION	Q'TY	MATERIAL / NOTE
1	Cabtyre Cable	1	PVC Sheath	52A	Upper Bearing	1	6000ZC3
20A	Upper Pump Casing	1	Plastic W/GF	52B	Lower Bearing	1	6201ZC3
20B	Lower Pump Casing	1	Plastic	53	Motor Protector	1	
21	Impeller	1	Plastic W/GF	54	Shaft	1	316 Stainless Steel
25	Mechanical Seal	1	D-12RC	55	Rotor	1	
30	Oil Lifter	1	Plastic	56	Stator	1	
35	Oil Plug	1	304 Stainless Steel	60	Bearing Housing	1	Aluminium Die Casting 12
36	Lubricant		Liquid Paraffin(ISO VG32)	64	Motor Frame	1	304 Stainless Steel
46	Air Release Valve	1	Glass Ball	68	Handle	1	Plastic
48	Screwed Flange	1	Plastic W/GF	76	Capacitor	1	
50	Motor Bracket	1	Aluminium Die Casting 12				
51	Head Cover	1	Plastic W/GF				

TSURUMI MFG. CO., LTD.

Created on: 2025-03-11

All data shown are not binding. Tsurumi reserves the right to change data and dimensions without notice.