

# **RSR Series**

**Rotary Blower**

## **OPERATION MANUAL**



**TSURUMI MANUFACTURING CO.,LTD.**

## INTRODUCTION

Thank you for selecting the Tsurumi RSR-series Rotary blower.

This instruction manual explains the product operation and gives important precautions regarding its safe use. In order to use the product to maximum benefit, be sure to read the instructions thoroughly and follow them carefully.

To avoid accident, do not use the product in any way other than described in this manual. Note that the manufacturer cannot be responsible for accidents arising because the product was not used as prescribed. After reading this operation manual, keep it nearby as a reference in case questions arise during use.

When lending this product to other party, always be sure to include this manual as well.

If this manual should become lost or damaged, ask your nearest dealer or Tsurumi representative for another copy.

Every effort has been made to ensure the completeness and accuracy of this document. Please contact your nearest dealer or Tsurumi representative if you notice any possible error or omission.

The contents of this document may not be copied in whole or in part without the express permission of Tsurumi Manufacturing Company, Limited.

### CONTENTS

1. PARTS NAME	1
·Assembly of Standard Blower	
·Construction of Blower Body	
2. CAUTIONS TO SAFETY	2
3. PRIOR TO USE	2, 3
4. INSTLLATION	3, 4
5. PIPING	4, 5
·Instructions to Mounting Check Valves (Type DCV)	
6. WIRING	5, 6
7. CHECKS BEFORE OPERATION	6, 7
8. INSTRUCTIONS TO OPERATION	8, 9
9. MAINTENANCE AND INSPECTION	9~14
·Brand Names of Oil and Grease	
·Amount of Oil and Grease	
·Check of Filter Element	
·Tensioning of V-belt	
·Safety Valve	
10. TROBLE SHOOTING	15~17
11. EXPLODED VIEW OF TYPE RSR	18

# 1 PARTS NAME

## Assembly of Standard Blower

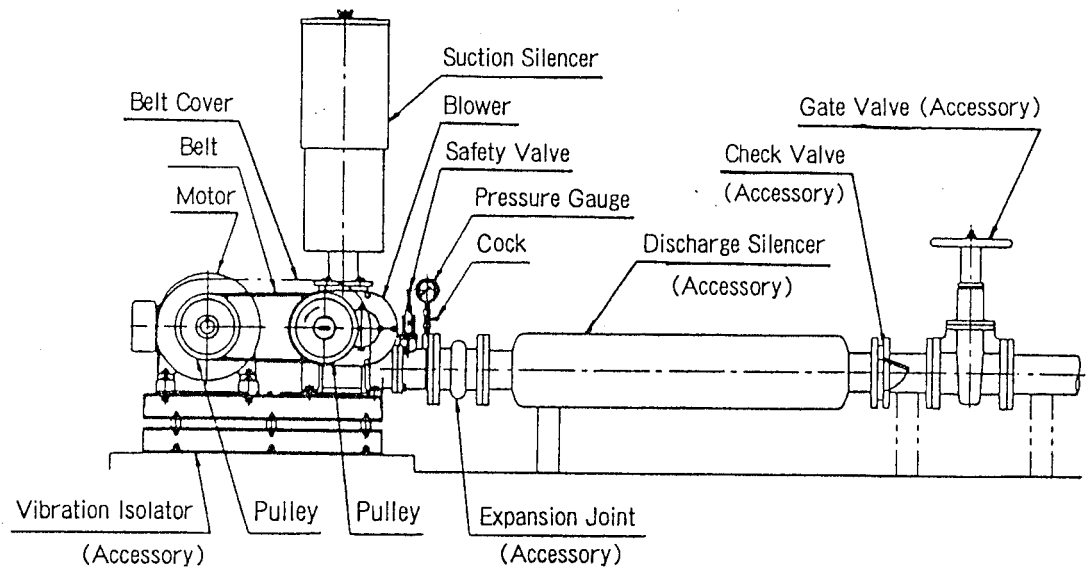

## Construction of Blower Body

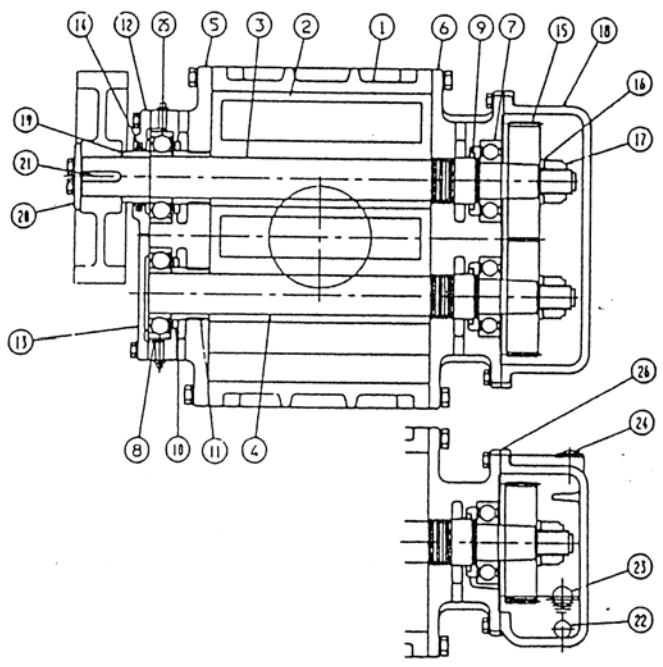

No.	PARTS NAME	Q'ty
1	Casing	1
2	Impeller	2
3	Drive Shaft	1
4	Driven Shaft	1
5	Side Cover(Drive Side)	1
6	Side Cover(Gear Side)	1
7	Bearing(Gear Side)	2
8	Bearing(Drive Side)	2
9	Stop Ring(Gear Side)	2
10	Stop Ring(Drive Side)	2
11	Bearing Sleeve	2
12	Bearing Cover(Drive Side)	1
13	Bearing Cover(Driven Side)	1
14	Z Seal	1
15	Gear	2
16	Gear Lock Washer	2
17	Gear Lock Nut	2
18	Gear case	1
19	Collar	1
20	End Plate	1
21	Parallel Key	1
22	Drain Plug	1
23	Oil Gauge	1
24	Air Breather	1
25	Grease Nipple	2
26	Gear Case Packing	1





**Note:** For gear lock nut 17 for RSR-150, use the nut for ball and roller bearing.

For further details, please refer to the exploded view in the last page hereof.

## 2 CAUTIONS TO SAFETY

The following caution marks are used in this manual.

Each mark has the following meaning.

Mark	Denotation
 <b>WARNING</b>	Potential risks resulting from improper handling, as it can cause death or serious injuries of personnel.
 <b>CAUTION</b>	Potential risks resulting from improper handling, as it can cause personnel injuries or material damages.
	Requires careful attention, as denoted in the note symbols or letters inside or near the triangle.
	MUST-NOT-DO'S; details are denoted by symbols or letters inside or near the mark.
	MUST-DO'S; details are denoted by symbols or letters inside or near the mark.

## 3 PRIOR TO USE



### WARNING

- The serviceable gas for this Blower is the air of room temperature and at ambient pressure.
  - Use of any hazardous gas could cause its leakage from the seal.
  - Use of corrosive or erosive gas could cause damage of the machine due to rust inside.

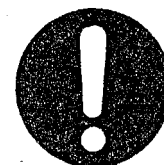

ONLY AIR  
SERVICEABLE

- Upon receiving the Blower, check:
  - If the name plate of the Blower indicates its specifications as ordered;

- If all accessories are furnished;
- If the Blower is free from breaks or dangerous caused in transit;
- In certain applications where air supply must be consecutive, such as fish raising, be sure to provide a spare Blower.

## 4 INSTALLATION



### WARNING

- In transferring or moving the Blower, exercise full care.
  - For create packing, do not lift the crate directly, as it could be broken and result injuries.
  - To transfer or move the Blower, lift by a band through the pallet at the bottom crate, or use fork lift.



MOVE WITH CARE



### CAUTION

- Do not install in the areas where inflammable or corrosive gases exist, e.g., solvents or paints.
  - If installed, it could be cause of fire or gas poisoning while servicing.
- Do not install in the areas where it is crowded or kids gather around.
  - If installed, it could be cause of injuries or burns while Blower is running.
  - A protection guard may be used to keep off people.
- Keep the Blower room temperature less than 40°C.
  - Higher temperature will make the life of Blower short significantly. Ventilators may be used to keep the temperature.

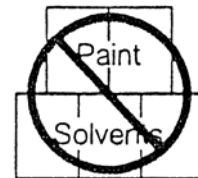

INSTALL IN  
BEST PLACE



NO HIGHER THAN 40°C

- Foundation must be rigid and solid, and its mounting surface be flat and higher than the grade.
- Location of the Blower should assure to provide a space nearby for disassembling and inspection.
- If the Blower is used outside, provide its roofing to protect from rains.

## **5 PIPING**

- Provide a flexible joint, in the piping not to have piping loads applied on the blower.
- The material of piping shall resist the discharge temperature and pressure. (Steel pipings are acceptable). Use of vinyl chloride pipings could be deformed and/or generate noise.
- The internal of piping should be clean and free from foreign substances.
- Where practical, provide a check valve to prevent a backflow into the Blower as a result of reversing.
- When disassembling, the Blower is to be disconnected from its piping. Therefore, in case of parallel arrangement, gate valves should be provided by all means so that it can be disassembled without stopping other blowers.

### **Instructions to Mounting Check Valves (Type DCV)**

- The vertical piping shall have no check valve, because it could be cause of noise, resulting from vibration of the valve disc.
- When the horizontal piping has a check valve, be sure to have a T bolt immediately above it.
- An arrow on the valve shall be in the same direction of air flow.
- Do not provide a gate valve or flexible joint immediately after the check valve. Otherwise, the check valve will not be open because of its size, and, as a result, abnormal pressure be applied on the Blower. Piping of carbon steel (SGP) shall be in accordance with the following table.

Type	DCV-50	DCV-65	DCV-80	DCV-100	DCV-125	DCV-150
Pipe Nom. Size (SGP)	50A	65A	80A	100A	125A	150A
I.D. (mm)	φ 52.7	φ 65.9	φ 78.1	φ 102.3	φ 126.6	φ 151.0

• Mounting

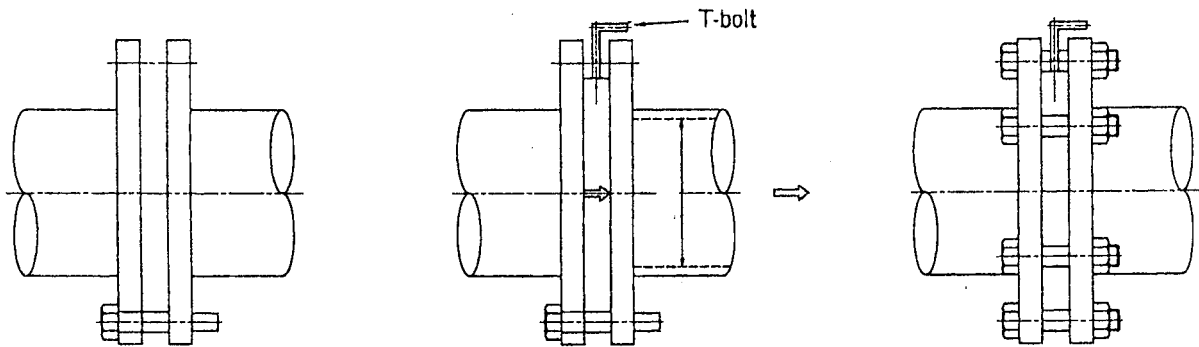

Put a number of bolts between flanges.

Put a check valve between flanges.

Put the remaining bolts and tighten with nuts.

## 6 WIRING



### WARNING

- Wiring and earthing shall be done only by qualified personnel.
  - Unsatisfactory or incomplete wiring by unqualified personnel can cause leakage or fire.
  - To prevent electric shocks or fire accidents, provide an earth leakage breaker and overload protector.
  
- Earthing shall be done surely.
  - Insure earthing will result in troubles such as failure or leakage.

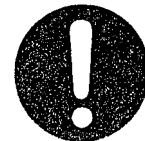

ENSURE WIRING



EARTHING



## CAUTION

- Power source cables shall be proper ones selected.
  - For longer distance and narrow cables, use care for possible seizing of motor and cables, lowering of the performance or breaking of the Blower.
- The turning direction of Blower is counterclockwise when seen from the pulley.
  - Reversing could include water in the machine, and break or damage it.



### PROPER CABLE

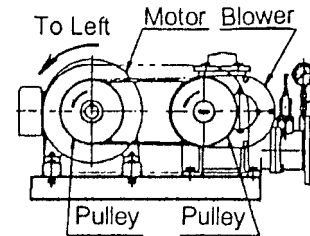

## 7 CHECKS BEFORE OPERATION



## WARNING

- Be sure to put on a belt cover.
  - No use of belt cover could have fingers or cloths caught in while operation, and cause injuries.

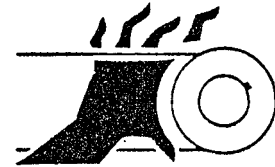

## CAUTION

- Open the valves in piping fully.
  - Keeping valves shut will cause an overload and result in braking of the machine.
- Be sure to supply gear oil.
  - Operation without gear oil will result in seizing of the gear and, as a result, make it broken. So, supply oil up to the level of gauge center when the Blower is stopped. Be noted that an excess oil will cause it to leak.

NO OIL IS IN THE BLOWER RECEIVED.



DO NOT SHUT VALVE

Oil Level

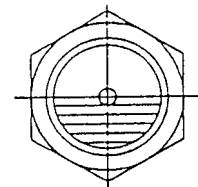

- Check tension of V-belt and alignment of shafts and pulleys.

- Insufficient adjustment of V-belt will shorten its life. V-belt may get loose or shafts and pulleys may be misaligned during transport or assembling, although it was adjusted prior to shipping. So, be sure to check it. To adjust the belt, see Section “Maintenance and Inspection”.



ADJUST BELT

- Check the turning direction of Blower by inching operation. Normally, it is counterclockwise, when seen from the pulley.

- Reversing could include water in the machine, or break or damage it.

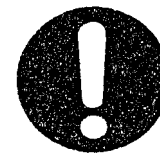

CHECK TURNING  
DIRECTION

- Check by turning the pulley manually to see if the Blower is free from irregularities.

- Inclusion of foreign substances make running dull or feel striking appreciably. In such a case, disassemble piping, and proceed with internal checks and cleaning of the Blower.



**WARNING**

- To check the Blower, stop it first.
- Use care not to have fingers caught in the pulley or belts.

- Grease the bearings.

- These are two grease nipples on the pulley side. So, grease by using a grease gun. Greasing shall continue until new grease will be over on the cast opening in the bearing cover. The Blower was greased prior to shipping.

## 8 INSTRUCTIONS TO OPERATION



### CAUTION

- During operation, do not touch the Blower, motor and accessories.
  - While operation, the Blower will have high temperature due to heat. So, use care not to burn.
  
- Do not regulate the air flow by opening/closing the valve.
  - The roots-type Blower has its air flow and power varied with the number of revolution, because it is displacement type. Shut-off of the valve will raise the pressure and cause an overload, which will result in damaging of the machine. Change the number of revolution, as appropriate, or provide air relief piping.
  
- In no case, shall the Blower be used in excess of rated values (as shown in the name plate).
  - Use of the Blower in excess of rated values will result in an overload and damage the machine. The rated current of motor, especially, shall be not higher than that shown in the name plate as an excess current can shorten its life.



CARE HIGH TEMP



DO NOT SHUT VALVE



NEVER OVERLOADED

- Keep the cock having a pressure gauge “shut”, only except when checking the pressure, because if it is kept open, then the life of pressure gauge shortened.
  
- Noise may vary with the Blower even in the same type. Also, it may vary with the internal condition of mechanical chamber or piping; in some case it can be higher than that shown in the catalogue.

- At the initial operation stage, the noise or current can be higher due to the viscosity of lubricant, which, however, should be returned to its normal condition in 10 to 20 minutes. When the discharge pressure is lower than 19.6 kPa (0.2kgf/cm<sup>2</sup>), or in case of intermittent operation, the lubricant temperature will not go high and the noise become higher due to higher lubricant viscosity. From such a reason, it is recommended that the existing oil be replaced with the one with lower viscosity (industrial multipurpose service oil (additive) ISO VG 68).

## 9 MAINTENANCE AND INSPECTION

Maintenance and inspection services shall be done on regular basis in accordance with the following procedure. However, these should depend upon the existing conditions, and therefore may be modified as appropriate.

 **WARNING**

- To start maintenance or inspection services, shut down the power first.
  - Abrupt operation start can lead to injuries by having fingers caught. To prevent such troubles, indicate “BLOWER NOW INSPECTED” to ensure that the concerned can know the situation. Note indicating [Stop] in the following table means the power must be shut down first when starting work.

  
 SHUT DOWN POWER FIRST

Maintenance and Inspection Table

Maintenance/ Inspection	Cycles				Remarks
	Da'y	Mo.	1Y	3-4 Y	
Pressure	○				Less than that shown in the name plate.
Air Flow	○				Specified value ±10%
Noise Level	○				No abnormal sound
Vibration	○				No abnormal vibration
Suction Air Temperature	○				Not higher than 40°C
Current	○				Less than specified value of motor
Voltage	○				Motor specified value ±10%

Maintenance/ Inspection	Cycles				Remarks
	Da'y	Mo.	1Y	3-4 Y	
Belt Tension and alignment [Stop]	○				
Gear Oil Amount [Stop]	○				Up to level gauge center.
Suction Silencer Cleaning		○			
Gear Oil Check [Stop]		○			Supply or replace full amount of oil.
Bearing Grease Check [Stop]		○			Supply or replace full amount of grease.
V-belt Replacement [Stop]			○		
Filter Element Replacement [Stop]			○		
Bearing Replacement [Stop]				○	Replace when disassembling.
Packing/seal Replacement [Stop]				○	Replace when disassembling.
Gear Check / Replacement [Stop]				○	Check and replace when disassembling.

\* It is recommended that the gear oil be replaced in its full amount in one month after initial operation.



### CAUTION

- Do not disassemble, repair or modify.
    - Disassembling, repairing or modification can be a cause of injuries or breaking of the machine.
- It must be done by a specialist.

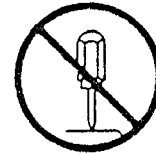

DO NOT DISASSEMBLE

## Brand Names of Oil and Grease

	Brand Name of Oil	Brand Name of Grease
Genuine	OMALA OIL 220 (Showa Shell)	MALTEMP SRL (kyodo Oil)
Recommended Brands	DAPHNY SUPER GEAR OIL (Idemitsu) BON KNOCK SP220 (Nippon Oil) SPARTAN EP220 (Esso) MOBIL GEAR 630 (Mobil) SP GEAR ROLL 220 (General) DIAMOND GEAR LUBE SP220 (Mitsubishi) REDUCTUS 220 (Kyoseki) MILD EP GEAR OIL 220 (Fuji)	Use genuine grease always. Should the brand in use be changed inevitably, use Li-soap base heat-resisting grease. In some combinations, mixing of dissimilar grease can make its property changed greatly. So, it needs care.

## Amount of Oil and Grease

Blower Type	Oil	Grease
RSR-50, 65	0.52ℓ	10g/port
RSR-80, 100	0.78ℓ	15g/port
RSR-125	1.6ℓ	23g/port
RSR-150	2.1ℓ	30g/port

- The oil / grease amount shown is for reference. Check it always by oil level gauge when the Blower is stopped.
- There are two grease ports.

## Check of Filter Element

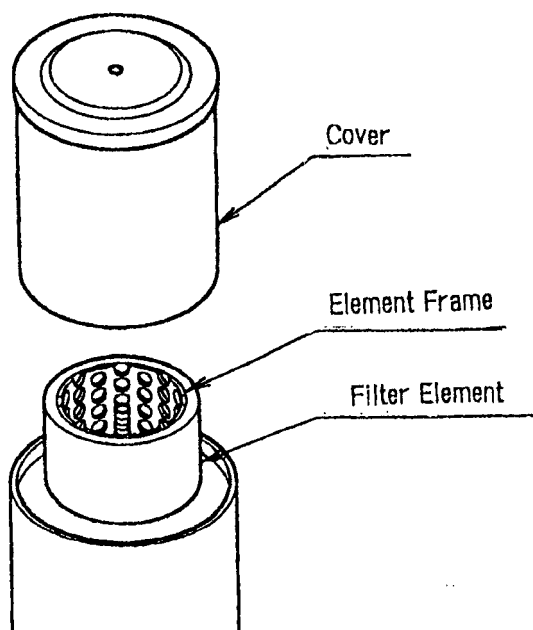

Remove the top cover of silencer.

Take off the filter element from the filter frame fixed in the cover, and check and clean the element.

Filter Element Size (mm)

Blower Type	I.D. x Height
RSR-50	φ 110 x 80
RSR-65	φ 135 x 90
RSR-80	φ 160 x 120
RSR-100	φ 185 x 150
RSR-125	φ 210 x 220
RSR-150	φ 240 x 300

## ■ Tensioning of V-belt

Alignment and tensioning of V-belt have been performed prior to shipping. But after running two or three days, the belt will be fitted and may get loose; therefore, it is needed to tension again.

[Procedure of tensioning]

<For type RSR-50~100>

- 1) Loosen the bolt of motor plate, and remove the belt.
- 2) Mount the belt, move the motor to the adequate tension and mark its position.  
Then, Remove the belt.
- 3) Adjust the pulleys of blower side and motor side aligned as the following figure by a carpenter's square.
- 4) Move the motor a little to the tension side that marked the position in 2). Then, tighten and fix the motor plate bolt.
- 5) Tension the belt.  
Use a tension meter to measure the tension of belt.
- 6) Confirm the alignment again by the carpenter's square. If there is a clearance over 1mm between carpenter's square and pulley, adjust alignment of the pulley again.

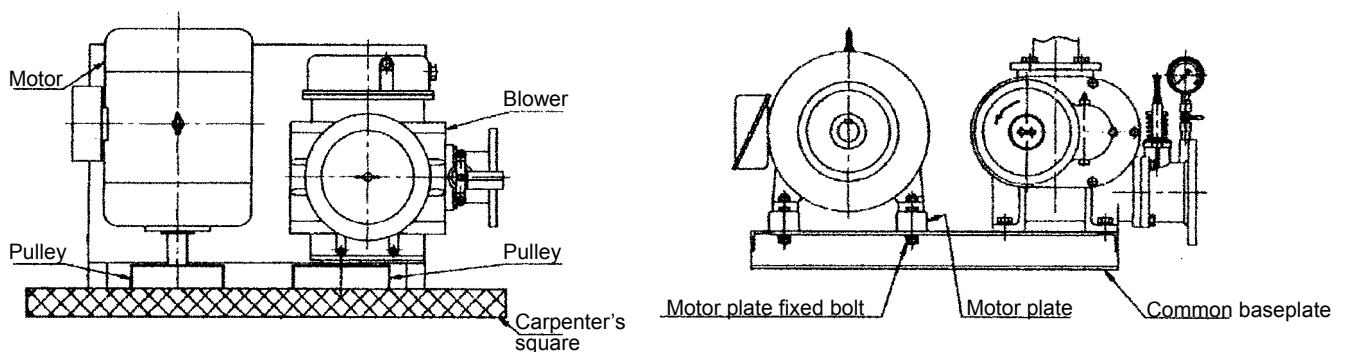

<For type RSR-125~150>

※Refer to the figure of following page.

- 1) Loosen the fixed bolt of motor plate with the belt attached.
- 2) With loosening the inner hexagon nut on the belt adjustment bolt located at the two corners of the baseplate (② in the fig.), tighten the outer hexagon nuts of both right and left sides (⑦) equally. This will slide the motor plate little by little, and the belt will be tensioned.
- 3) Confirm that the pulleys are properly aligned by carpenter's square after adjustment the tension of the belt.
- 4) Normally, as the amount of movement of rear side will be larger, loosen the outer hexagon nut on the adjusting bolt (①) of rear side of the motor. Tighten the inner hexagon nut(②), to move the motor plate of the rear side of the motor to the blower side (opposite to the tension side), and then adjust it.

- 5) Confirm again degree of alignment of pulleys.
- 6) Measure the belt tension by tension meter.
- 7) Finally, tighten the motor plate fixing bolts.

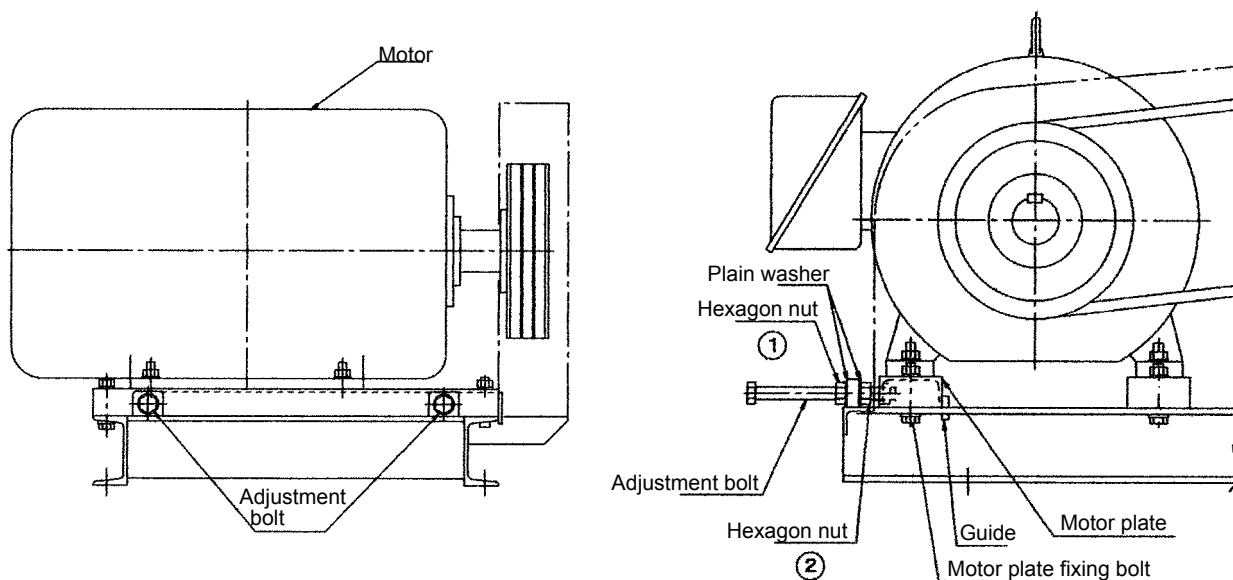

[Indication of tensioning of V-belt]

1) Tension loading of belt Wkg

Type of Blower	Tension loading
RSR-50~100	2.0
RSR-125	3.0
RSR-150	5.0

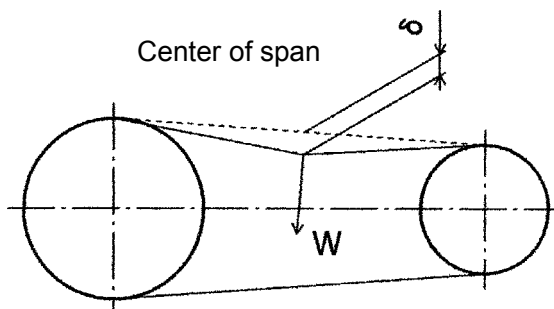

2) Deflection of belt  $\delta$  mm

Type of Blower	Deflection		
	New	First	Second
RSR-50~100	$4.0 \pm 0.5$	$4.5 \pm 0.5$	$5.5 \pm 0.5$
RSR-125	$6.0 \pm 0.5$	$7.0 \pm 0.5$	$8.5 \pm 0.5$
RSR-150	$5.5 \pm 0.5$	$6.5 \pm 0.5$	$7.5 \pm 0.5$

3) Time of tensioning

- 1) After running of 2~16hours, re-stretch to the first value.
- 2) After running of 1~2 weeks, re-stretch to the second or later value.

## Safety Valve

Safety valves are required to work at lower pressures, and so the valve seating surface and valve disc contact surface have been precision-finished. Therefore, if foreign substances are stuck on the surfaces near the valve seat, they could be caught in the valve seating surface, while the valve is working, which can cause leakage when the valve is stopped.

Also, a strong impact applied from outside could make the valve work unstably. So, transport requires utmost care not to drop or apply impact.

### <Pressure Adjustment >

The pressure for valve was adjusted to work at specified pressure, prior to shipping. Should the discharge pressure be found to have an error, readjust it as follows.

- 1) Loosen the lock nut ⑤.
- 2) Turn the adjusting screw ⑥ to adjust the pressure as specified.  
Turning of adjusting screw clockwise will make the discharge pressure higher, while turning it counterclockwise will make it lower.
- 3) tighten the lock nut ⑤.

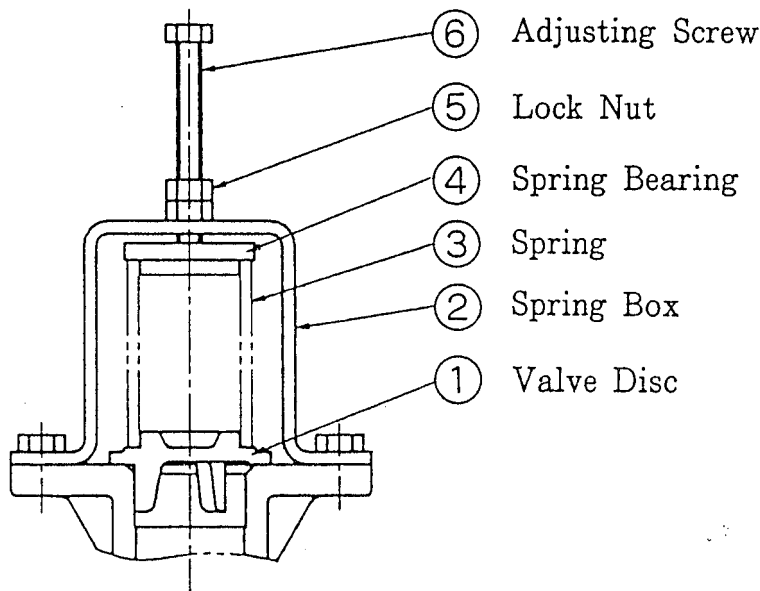

In some cases, a safety valve of special type which is different from the above shown may be installed, but the basic construction is the same as above. So, adjust it in the same procedure.

# 10 TROUBLE SHOOTING

		Troubles	Sources	Actions
Blower	Not turned	Can try by hand in either direction.	Motor is failed.	Repair or replace the motor,
		Can not turn even by hand.	Rotor is stucked.	Disassemble and repair.
	Foreign substances are included in the casing.		Disassemble and repair.	
	Turned	Abnormal noise or vibration.	V-belt is slipped or too much tensioned.	Disassemble and repair.
			Pulley is out-of- center.	Re-center the pulley.
			Belt cover interferes with the belt.	Reform the belt cover correctly.
			Bearing grease is deteriorated or running short.	Re-grease.
			Gear oil is deteriorated, running short, or in appropriate.	Re-supply gear oil.
			Safety valve is blown off.	Regulate safety valve.
			Strength of foundation is not enough.	Reinforce the foundation.
			Resonance of piping.	Provide silencer, support, etc.
			Discharge pressure is abnormally increased.	See the column with ※.
			Tightening to foundation is incomplete.	Re-tighten.
			Rotor interferes.	Disassemble and repair.
			Foreign substances are included in the casing.	Disassemble and repair.
Check valve is failed.	Replace the valve.			

		Troubles	Sources	Actions
Blower	Turned	Abnormal heat.	Discharge pressure is abnormally increased.	See the column with ※.
			Internal temperature of blower chamber is raised (higher than 40°C).	Increase ventilation.
			Suction silencer is blocked.	Clean/replace the filter element.
		Shortage of air flow.	Piping is leaked.	Re-tighten connections.
			Safety valve is blown off.	Regulate safety valve.
			Suction silencer is blocked.	Clean/replace the filter element.
			Belt is slipped.	Re-adjust belt tension.
			Discharge pressure is abnormally increased.	See the column with ※.
		※ Abnormal increase of discharge pressure.	Valve is shut off.	Open the valve fully.
			Water depth is increased.	Adjust water depth.
			Diffuser pipe is blocked.	Clean.
			Piping is blocked.	Clean.
	Check valve is failed, or set in a reverse direction.		Replace, or make direction opposite.	
	Air flow is excessive.		Reduce rotation speed, or escape air.	
	Oil leak.	Gear oil is excessive.	Adjust it up to level of gauge center (at stop).	
Motor	Not turned	Can turn by hand in either direction.	Contact of switches or wiring is failed.	Correct the contact, or replace.
			Fuse or a single cable is disconnected.	Check, repair or replace.
			Power supply is abnormal.	Re-work the power supply installation.
			Motor is failed.	Repair or replace motor.

		Troubles	Sources	Actions
Motor		Cannot turn even by hand.	Bearing is defective.	Replace bearing.
			Motor is failed.	Repair or replace motor.
	Turned	Reversing.	Connection is incorrect.	Check connections.
		Abnormal heat.	Overloaded.	Re-adjust discharge pressure.
			Power supply is abnormal.	Re-work the power supply installation.
			Internal temperature of blower chamber is raised (higher than 40°C)	Increase ventilation.
		Rotation speed not increased.	Power supply is abnormal.	Re-work the power supply installation.
			Overloaded.	Re-adjust discharge pressure.
	Excessive current. high	Discharge pressure is abnormally increased.	See the column with ※.	
		Suction silencer is blocked.	Clean/replace the filter element.	
		Power supply is abnormal.	Re-work the power supply installation.	

### **Disposal of Product**

Properly dispose of the product by disassembling it, presorting the contents, and sending them to the waste material treatment site.

# 11 EXPLODED VIEW OF TYPE RSR

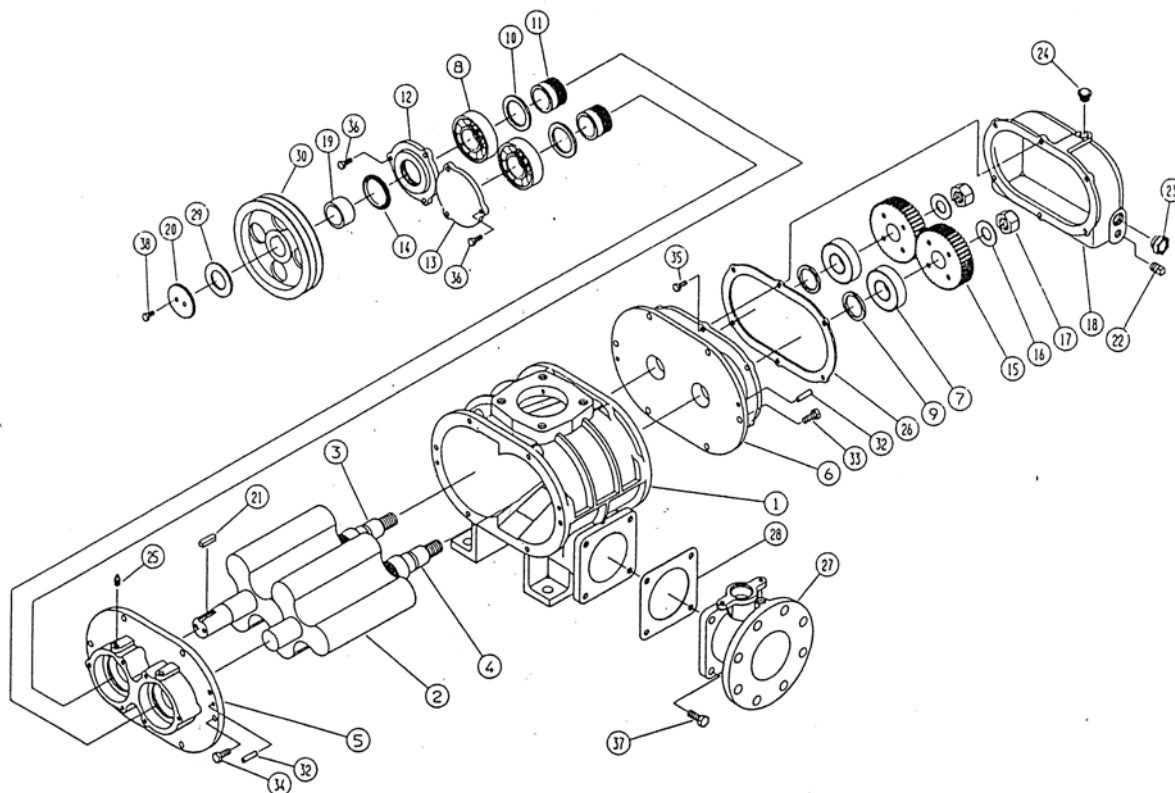

No	Name	Material	Q'ty	No	Name	Material	Q'ty
1	Casing	FC200	1	20	End Plate	SS400	1
2	Impeller	FC200	2	21	Parallel Key	S45C	1
3	Drive Shaft	S45C	1	22	Drain Plug	FCMB	1
4	Driven Shaft	S45C	1	23	Oil Gauge	SS+ Glass	1
5	Side Cover(Drive Side)	FC200	1	24	Air Breather	Resin	1
6	Side Cover(Gear Side)	FC200	1	25	Grease Nipple	C3601B	2
7	Bearing	SUJ2	2	26	Gear Case Packing	Three Sheet	1
8	Bearing	SUJ2	2	27	Reducer	FC200	1
9	Stop Ring(Gear Side)	NBR	2	28	Reducer Packing	EPDM	1
10	Stop Ring (Drive Side)	NBR	2	29	Spacer	SS400	1
11	Bearing sleeve	S45C	2	30	V-pulley	FC200	1
12	Bearing Cover(Drive Side)	FC200	1	31			
13	Bearing Cover(Driven Side)	FC200	1	32	Taper Pin	S20C	4
14	Z Seal	NBR	1	33	Hex. Bolt	SS400	6
15	Gear	SCM435	2	34	Hex. Bolt	SS400	6
16	Gear Lock Washer	FC200	2	35	Hex. Bolt	SS400	6
17	Gear Lock Nut	SS400	2	36	Hex. Bolt	SS400	6
18	Gear Case	FC200	1	37	Hex. Bolt	SS400	4
19	Collar	S45C	1	38	Hex. Bolt	SS400	2

※Depending upon the size of pulley, the spacer 29 may not be furnished.

For types RSR-125 / 150, the quantity of hexagon nuts 33, 34 and 35 will be 8. For RSR-150, the type of nut 17 will be lock washer and locknut for rolling bearing.